



# Boardwalk Design Guide

Revision 2



**Outdoor Structures  
Australia**  
*outlasts and outperforms*

# Contents

<b>2</b>	<b>Introduction</b>
	General
<b>3</b>	<b>Timber in Boardwalks</b>
<b>4</b>	<b>Design Standards</b>
<b>4</b>	<b>Location</b>
	Wetlands
<b>5</b>	<b>Hazards</b>
<b>5</b>	<b>Preliminary Layout</b>
<b>6</b>	<b>Alignment</b>
	Vertical
<b>6</b>	<b>Recommended Grades</b>
<b>7</b>	<b>Substructure</b>
<b>8</b>	<b>Superstructure</b>
	Golf cars
	Recommended Widths
<b>11</b>	<b>Edge Treatment</b>
<b>16</b>	<b>Structural Systems</b>
<b>18</b>	<b>Construction Requirements</b>
<b>19</b>	<b>Design &amp; Construction with Hardwood</b>
<b>24</b>	<b>Engineering Design Standards</b>
	Decking Design
	Concentrated Loads on Decking
<b>30</b>	<b>Substructure</b>
<b>33</b>	<b>Wetland Boardwalks</b>
	Deck Alignment
<b>35</b>	<b>South Queensland Forest Agreement</b>
	Conclusion
	References

## Introduction

Boardwalks can range from narrow nature trails in fragile wetlands to wide beachfront entertainment decks; from golf course access to paths linking facilities in ecotourist projects; from recreational cycleways to observation decks in tourist parks; from fishing piers to small scale jetties. They are a convenient way of providing a safe, easy walk, free from dirt and pools of water. Boardwalks are frequently chosen purely for the natural look and feel of timber. Added to this is the renewable nature of the material, its versatility and, often more importantly, for its reduced impact on the surroundings during construction and use. It provides a welcome alternative to concrete or asphalt and facilitates the construction of easy grades that encourage walking for an extended range of users.



**Fig1 - Golf course access**

A boardwalk is simply a raised walkway with a surface made up of boards; usually arranged across the direction of travel. It is a pedestrian bridge with low, short spans, but without the waterproofing benefits of bituminous surfacing. Since decking is exposed to the ravages of weather and traffic, it has to withstand one of the most demanding situations placed upon timber. This publication has been developed specifically to raise the understanding and knowledge of professional designers and constructors of timber boardwalks. This publication has been produced for Outdoor Structures Australia by James Pierce & Associates, Consulting Engineers. The information shown herein does not constitute a complete design so a Consulting Engineer with skills in both timber design and foundation systems should be engaged for the structural and foundation design. Additionally interpretation of the foundation material should be entrusted to a Geotechnical Engineer as many boardwalk locations have extremely poor soils. While care has been taken to ensure coverage of the design principles for boardwalks, the versatility and adaptability of this form of construction is only touched on here and so the information must be regarded as incomplete.

## General

Boardwalks can often replace conventional footpath construction resulting in:-

- less damage during construction
- less erosion problems caused by the construction processes
- no revegetation needed because of minimal construction disturbance
- no change in drainage patterns (and subsequent effects on flora & fauna) caused by the damming effect of pavement construction or concentration of water by use of stormwater pipes
- constraining the users to the defined pathways and all but eliminating damage to the flora in service.
- no extra space required for fill batters and less interference to the roots of trees. The versatility of this construction means that pathways can be constructed where conventional tracks/footpaths are impractical or self defeating (i.e. the track construction often degrades the very environment that it was installed to showcase).

Designers, inexperienced in boardwalk construction, have a tendency to use traditional footpath construction methods and are not completely aware of the many advantages of boardwalks. Also factors necessary to take into account in the concept plans are beyond their experience *e.g. in a wetlands environment it is important to get the viewer as close to the water as practical while positioning the structure so it is minimally affected by extreme tides, storm surge and flood.*

Walkway construction in sensitive environments is complicated by many variables. The design requires a broad experience of local conditions and should only be attempted by trained professionals. Due attention should be given to the intended users, environment, aesthetics, available equipment and construction skills.

Proper evaluation of soils is critical to the economy of the system and the performance of the walkway. In most walks, the underfoot conditions are poor and variable. A detailed soils evaluation of the site enables more informed design decisions as well as reducing the risk for the contractor. A more detailed discussion of possible foundation systems follows later in this Guide.

## Timber in Boardwalks

Timber promotion agencies have been very successful over the last 20 years in promoting quality assurance processes for structural timber and developing an awareness of the F (strength grades) rating. However just specifying a high F grade is not enough for trafficked and handled surfaces. Even for appropriate timber species exposed to the weather, defects visible to the trained eye permit lodgement of water and can lead to premature decay and poor appearance with raising of grain and development of splinters when exposed to sun and rain within a short period.

For a satisfactory boardwalk exposed to the full ravages of weather, timber species that are tough, stable, durable and resistant to UV degrade are necessary. Additionally the surface exposed to the weather has to be free of defects that may be hazardous to the public many years later or may contribute to premature degrade of the decking in service.

Deckwood™ is the name of the quality hardwood decking developed exclusively by Outdoor Structures Australia. It features unique patented profiles, treatment and species specifically for external structures. Outdoor Structures Australia visually grades the upper surface for superior appearance and performance. Detailed specifications are contained in its Deckwood Selection Guide.

The longevity of external timber structures also depends on the design and execution. Often just a few typical details are shown on engineer's working drawings but more extensive detailing is required for workshop drawings where virtually every circumstance has to be thought out in advance of assembly. This also applies to site construction where the carpenter may not have extensive knowledge and experience in these types of structures. The detailing requires visualizing the three dimensional structure and applying both craftsmanship and the engineer's intent to produce the finished structure.

One of the strengths of Outdoor Structures Australia is that, as a manufacturer, the company understands the workshop detailing required to construct good structures in-house. It can provide the same standard and completeness of detailing for structures built on site; even for carpenters unfamiliar with these structures. When assessing tenders for a project, quality of the timber, workshop details and workmanship are rarely known by the potential client. That is a great pity as the long term performance of these structures is dependant on these attributes.

## Design Standards

Boardwalks may be required to conform to the BCA (Building Code of Australia) where they form part of access to, or between, buildings or to AustRoads Bridge Code where they form an extension to a bridge. Alternatively they can be considered to fall under the jurisdiction of pedestrian facilities (AustRoads & SAA HB 69.13-1995 - Pedestrians) or even cycling facilities (AustRoads & SAA HB 69.14-1995 - Bicycles).

Additionally a client may require that the facility comply with the requirements for people with disabilities and this often includes people in wheel chairs or gophers, people with walking aids such as crutches or walking sticks as well as the poorly sighted (AS 1428.1 & 2 Design for access & mobility Part 1 & 2).

However many boardwalks provide an adventure role and are often a part of a recreational walking track (AS 2156.2 Walking tracks Part 2: Infrastructure design). Unrealistically high loads can have major cost consequences (especially piling and connections) while enthusiastic use of railings can present an all too unnatural nature walk. At the outset the designer has to select the design loads and the railing requirements, both of which impact on the appearance and cost of the structure.



**Fig 2 Mangrove walk to birdhide**

It is suggested that a Risk Analysis be carried out on the decision making for each type of boardwalk use. The main aspects that require attention are the loadings and the railing.

What is the probability of an overload?  
What is the consequence of an overload?  
What is the consequence of not having a full railing with balusters?

For instance, a 1.2 metre high barrier is mandatory for a swimming pool surround to exclude unsupervised small children. While a creek under a boardwalk may be a similar hazard, it may be reasonable to expect that small children would be under parental supervision and so the barrier need not be as substantial.

## Location

The proposed location will dictate the appearance of the boardwalk, the design intent and the construction methods to be adopted.

## Wetlands

### Marine

In Australia most of the rainfall and population is confined to the periphery of the continent so correspondingly many of its popular wetlands are in marine or brackish environments. (*Mangrove trees grow only in marine environments.*) Marine borers destroy most timbers within the tidal zone and appropriate measures have to be taken to reduce attack (refer to section on marine borers).



**Fig 3 Treated pine piling with UPVC shields in marine**

Since the main use of marine boardwalks is recreational, it is unlikely that they will be used during extremes of weather (as opposed to those serving trips to work/education). For economy and protection from wave splash, all timbers (headstock and above) shall be above the extreme water level (occasional wetting is not a problem). On the other hand, wetland boardwalks are most effective when they are close to the water level. Tidal ranges vary depending on the latitude and the local influences e.g. how far up an estuary (tidal information is normally available from the harbour, marine or transport authority).

### Freshwater

Freshwater environments are usually less restrictive but be aware that marine conditions can apply in brackish water even 20 kilometres from the sea. In true freshwater there are no marine borers, wave action is typically less due to smaller bodies of water, more shelter from the wind and less vessel-induced wash.

Factors to be considered in choosing a deck level:

- Normal water level and its typical range from wet season to dry,  
(*keep the deck as close as practical to the water*)
- Wave action depending on exposure/shelter
- Consequences of submergence
- Effect of the structure on flood levels upstream.
- Flood levels and corresponding flow velocity.
- Likely debris.

(*Further points to be considered in deciding on a deck level are given later.*)

## Rugged Country

In rocky country a boardwalk may be the only practical way of providing access. Supports may need to be rock anchors or, at the very least, cored into rock. As supporting columns may not carry a moment into the rock, the structure may have to be stabilized with bracing elements.

## Hazards

There are a few points that need to be considered that may not be obvious from a cursory field inspection: services and leaf litter.

### Services

Underground services, especially sewerage and underground power, can often be a hazard to construction where footing excavations or piles are required. Service authorities should be contacted before final location of the boardwalk is fixed. The adaptability of the systems allows the boardwalk to straddle the obstacle provided its accurate location is known. Access may have to be provided to allow access to pits for maintenance and so the height of the deck may have to be raised or an access hatch cut into the decking.

### Leaf litter

Decking can entrap leaf litter, fruit and twigs. The problem depends very much on the surrounding tree species. If the planks are widely gapped with a kerb spaced above the deck, wind action may assist in removal of this rubbish. So a deck with narrow boards, spaced well apart and no kerb, requires less cleaning. Supplementary cleaning needs to be done using a blower/vac or compressed air periodically, the frequency depending on the foliage and exposure. Twigs and branches have to be removed by hand. Removal of litter is important to ensure the longevity of the deck as, otherwise, the decomposition of the litter introduces an increased rotting hazard for the deck. Also surface debris can increase the slip hazard.

## Preliminary Layout

Apart from a straight boardwalk over reasonable ground (and that is rare), most walks are in difficult country so the deck alignment has to conform to many demands:

- height above water level
- grade less than 3% preferred
- vertical clearance overhead
- wind between various trees, even trees within the deck
- access viewing spots
- curves in plan
- construction tolerance

and so the list goes on.

These demand that the structural system be adaptable to keep construction simple. For this reason, the pegged foundations should not adopt the maximum span for the system but somewhat less. This allows the person laying out the work to have some latitude in seeking the best foundation location (*avoiding floaters and roots*), while not exceeding the structural limitations.

Initial investigatory work would include:

- the flooding/tidal profile
- the natural ground surface level
- the nature of the ground.

An investigatory line (*and alternatives*) needs to be marked so it can form the basis for design, estimating and construction.

The line can be established by:

- engineering survey (*pegged line and levels*)
- contour plans
- chain, compass and clinometer with adjacent obstacles/features being marked with flagging tape as an aid to construction.

Some temporary benchmarks and other recovery marks may have to be established as well as property/lease boundaries. In inundated areas, the depth of water can be measured and related to the tide at the time by placing a peg at the water level and later correlating this with the height datum (*often AHD - Australian Height Datum; which is different from the tidal or port datum*). Pegged piling positions are easily disturbed by the piling equipment so offsets are required, well clear of construction. In non-marshy ground, it may be sufficient to mark the ground with a cross at every pile position. Hydrated lime poured

out of a plastic bottle (*like sports field line marking*) (*temporary only*) or survey spray paint (*an upside down spray can*) are effective. In situations where foundation locations govern the handrailing line, much more care has to be taken so that the finished line is acceptable to the eye. Engineering surveyors may be needed then to set out an even curve.

For every metre of the walk the proximity of the trees, overhanging foliage, and the change in direction must all be assessed in deciding on the final alignment. Once the foundations are installed, it is difficult to alter. Remember that, when close to some obstructions, the final level of deck and railing may govern the foundation location so one has to look overhead (*considering the final deck level*) as well as below.

## Alignment

The grades and meandering of a walk are referred to as the alignment. The vertical alignment refers to the deck levels while the horizontal alignment refers to the plan layout. There are various requirements to be met depending on the expected users.

### Vertical

AustRoads allows walkways to be graded to 12.5% (1:8) and 1:1.6 for stairways. Cycleways would normally be restricted to 5% desirable grades with less than 3% preferable.

If the facility has to comply with AS 1428.1, (*Design for Access & Mobility*) walkway grades less than 3% (1:33) are preferred if rest platforms and handrails are to be avoided. At the other extreme 7% (1:14) is the maximum ramp grade but level rest platforms have to be provided every 9 metres and this often breaks the rhythm of the alignment.

Even though the decking is free draining, there may be an alignment need to provide crossfall (e.g. connecting to a lookout). AS 1428.1 specifies a maximum of 1:40 (2.5%). Cycling speed on boardwalks needs to be restricted to 15 km/h due to the nature of the surface, purpose of the structure and especially if it is shared with pedestrians. Smaller board widths can be used to restrict speed somewhat by building-in a corrugation of sorts. Recent trends towards fatter cycle tyres and suspension seem to have reduced the effectiveness of this.

Sometimes the designer may provide two routes (*especially in circuit walks*) where one portion is not accessible for the disabled (due to grade or stairs) while another portion is.

In wetland environments boardwalks are invariably flat. There may be a small increase in level of sections of walks exposed to wave action compared with sections sheltered by vegetation to give the same immunity to overtopping but the ramps between these sections should have no difficulty in meeting a 3% grade. Along permanent waterways such as creeks & rivers there may be a gradient equivalent to the flowing water surface but this would rarely be greater than 3% (*except for rapids and cascades*).

## Recommended grades

A recommendation satisfying all users:

- 3% grade generally
- 7% grade ramps connecting differences in level of less than 0.63m (*i.e. ramps no longer than 9 metres*)

### Horizontal Alignment

Walking and jogging rarely govern alignments. While cycling routes are often designed for 30 km/h, recreational cycling needs to be restricted to 15km/h in the normal application of these structures.



Fig 4. Ramped boardwalk providing access to campus building

**TABLE 1 - HORIZONTAL CURVES**

Horizontal Alignment to suit Bicycles - 15 km/h Design Speed

	AustRoads - Bicycles	
	Radius	Approx angle change in 3m chords (degrees)
Minimum	5m	35
Preferred	8m	22

An 8m radius also meets the minimum requirement for a 20km/h cycle speed.

### Vertical Clearance

A pleasing walkway often owes its character to the way it harmonizes with the vegetation, flowing from tree to tree, providing new vistas at every turn. Sometimes trees are incorporated into the deck itself rather than changing the alignment or lopping. It is necessary to ensure that such incursions do not become undue hazards. It is quite common on walking tracks for sections to be narrow or of limited headroom. On boardwalks there may be an expectation that there should be less intrusion into the travelled way. And don't forget that, due to growing vegetation, there may be a need for judicious pruning to maintain these clearances.

**TANALISED®**  
**TABLE 2 - VERTICAL CLEARANCES**  
 Vertical Clearances

	BCA		AustRoads			
	Rooms	Doorways & Stairs	Pedestrians	Bicycles	Bridge Design	
					Pedestrians	Bicycles
Minimum	2.1m	2.0m	2.0m	2.4m	2.0m	2.4m
Preferred	2.4m		2.4m	2.7m	2.4m	2.7m

Based on this table it is recommended that a vertical clearance of 2.1 m be provided and, for shared walks or exclusive bicycle ways, increased to 2.7m. Clearances to overhanging branches may be somewhat less than this in rest areas where the likelihood and consequences of hitting your head are less.

## Substructure

The foundation cost has a big impact on the viability of a boardwalk. This is because the site often has very poor ground with difficult access. Table 3 gives a summary of the more likely foundation types.

**TABLE 3 - FOUNDATIONS SELECTION**

Ground Conditions	Rock	Stiff Ground	Soft Ground	Watertable
Foundation Type	Drilled or cored	Potted pier	Piled or Bedlog	

# Superstructure

TABLE 4 - PEDESTRIAN BRIDGE WIDTHS (*between rails*)

Bridge Design Code - AustRoads	Proposed System
1.8 m min. (caters for 300 persons/hour) (AS 1428.2 - allows 2 wheelchairs to pass)	2.0 m (ex 2.1 m plank lengths)

TABLE 5 - BICYCLE BRIDGE WIDTHS (*between offset rails*)

Bridge Design Code - AustRoads	Proposed System
<b>One-way only</b>	
2.0 m min.	2.0 m (ex 2.4 m plank lengths)
<b>2 way</b>	
3.0 m min.	3.0 m (ex 3.6 m plank lengths)

TABLE 6 - SHARED BRIDGE WIDTHS (*between offset rails*) (CYCLISTS & PEDESTRIANS)

Bridge Design Code - AustRoads	Proposed System
3.0 m min.	3.0 m (ex 3.6 m plank lengths)

TABLE 7 - WALKING TRACK BRIDGE WIDTHS (*between rails*)

Walking Track Pt 2: Infrastructure design	Proposed System
(Widths not Specified in AS 2156.2) Class 3 Class 4 & 5	1.7 m Class 3 (ex 1.8 m plank lengths min for quad bike) 1.5 m Class 4 & 5

## Golf cars

Typical width of a golf car is 1200mm. A 200mm clearance to kerbs on both sides gives a desirable minimum deck width of 2.0m (*including kerbs*). When approaches to the bridge are skewed, an increase in width is desirable. For decks longer than 10m, pedestrian refuges in the form of local widenings are desirable. For two way movement or, for shared facilities with significant pedestrian movement e.g. golf tournaments), a deck width of 3.5m is the minimum.

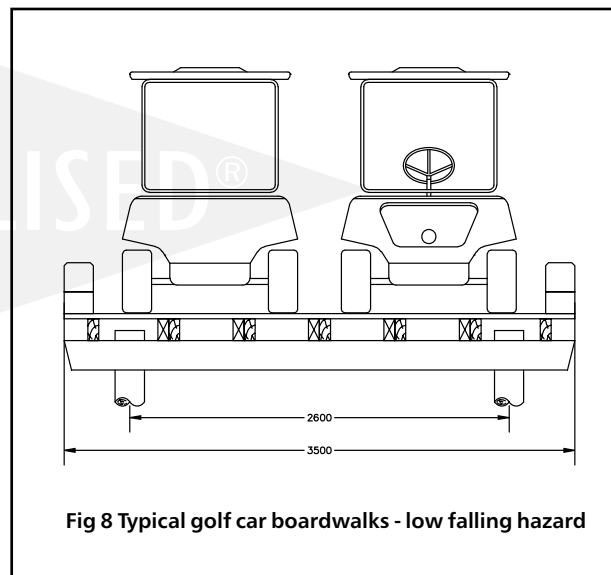
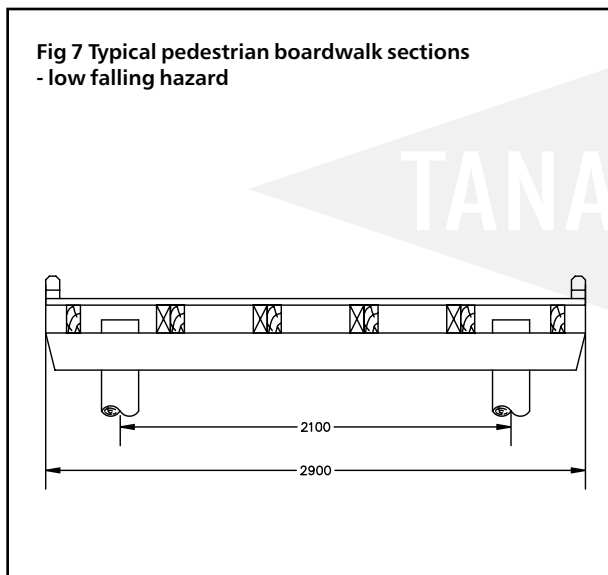

Fig 6 Golf car path with easy curves

# Recommended Widths

TABLE 8 - RECOMMENDED BOARDWALK DECK WIDTHS

Clear Width	Application
1.5 m	Low volume of pedestrians only, bicycles prohibited, not suitable for disabled
1.7 m	Minimum for 2 wheel chairs to pass
2.0 m	Preferred width for pedestrian boardwalk, or 1 way cycling, or 1 way golf cars
3.0 m	Minimum for shared facility (pedestrians and cyclists), or 2 way cycling
3.5 m	Minimum for 2 way operation of golf cars, or 1 way operation of golf cars shared with pedestrians



## Widenings, Transitions & Junctions



Fig 9 Boardwalk three way junction with truncation

Widenings need to be provided at intervals to allow congregation of groups, passing and rest opportunities. OSA make a range of seats that can be integrated into a design. Sometimes these wider sections can include variations in level to suit different users and to provide seclusion and different vantage points.

At the junction where walks meet there needs to be an enlargement because of the traffic movements as well as providing waiting areas. The resulting framing needs to make the decking intersections easy and logical.

## Platforms, Shelters & Birdhides

Lookouts or rest platforms may need to meet the requirements of the BCA or Walking Tracks (AS 2156.2) with regard to crowd (*panic*) loadings on both deck and handrails. Swimming pool fencing, that is somewhat impenetrable to small children, may be appropriate as balustrading. This may be necessary as parental supervision of small children is likely to be distracted at these locations due to viewing or rest situations.

Fixed seating and shelters provide additional opportunities for enjoyment of the environment, encouraging use of these facilities by the aged and infirm. Seating should be located off the travelled way and preferably with a view.



Fig 10 Seat widening

On long walks, a simple shelter shed can provide welcome refuge from sun and rain. The shed should be constructed in sympathy with the boardwalk and the natural surroundings and located on a widening.



Fig 11 Shelter incorporated into long walk

In places where bird activity is concentrated, a birdhide, walled on at least two sides, may be a further incentive for using the facility. Outdoor Structures Australia can assist in both the design and construction of these shelters as well as in a varied range of park buildings.



Fig 12 Birdhide

## Terminations

To achieve a long lasting structure, about 0.6 metre is required between the ground and the deck level in typical construction so that vegetation is kept clear of fire and durability. At some point there must be a transition from boardwalk to paved footpath.

This may be accomplished by several means:

- terminating the boardwalk on a higher section of natural ground
- terminating the boardwalk on an embankment and then grading down to the natural surface
- using Durability 1 timbers and partly burying the last 9 metres.
- making a transition into a chain ladder (*can be supplied by Outdoor Structures Australia*) where a roll of timber is connected by galvanized chains and laid on a good draining ballast (*very similar to railroad tracks*)
- using steps (*timber framed, sleepers or stone or concrete stairs*) but these can only be used in sections where cyclists and disabled are not anticipated.
- abutting a concrete structure (*care with differential shrinkage here*).



Fig 13 'Cul-de-sac' features the view, interpretive information and seat

## Perimeter types

Types from simplest to more complicated:

- none
- kerb only
- high kerb only
- stanchions / bollards only (could be used in conjunction with draped ropes or chains as visual barriers only)
- top rail only
- top and intermediate rail
- top rail with wire rope
- top and bottom rails and balusters where small children must be restrained.

## Edge Treatments

### Handrails

Information on handrails is presented here as possibilities only. The designer should assess the policy of the local authority and make choices based on risk assessment of the actual site and its anticipated users. It may be prudent to adopt a system that permits retrofitting of rails as community and boardwalk users' expectations may change with time.

The purpose of handrails are many:

- confining the user to the boardwalk to prevent damage to the environment
- guiding the user, particularly the partially sighted and for walks used at night e.g. viewing platforms for night views
- preventing falls from the boardwalk especially when the consequences could be serious e.g. on to rocks, into deep water.
- providing rest opportunities - to lean against
- crowd control - to avoid being pushed over edge
- providing for the disabled.

Disadvantages of handrails include:

- increased cost
- visually intrusive especially in nature walks
- debris catchers especially in walks that can be submerged in flood
- nearer the eye height so minor misalignment, poor workmanship, and timber defects are more evident i.e. requires competent carpenters.
- handled surfaces have to be clean and free of splinters.



Fig 14 Boardwalk Cycleway

The infill (under the top rail) could be stainless steel wire as it maximizes the view while providing some measure of restraint but it does not appear to meet the intent of the BCA or AustRoads where the fall is significant. It could be argued that the wires can be spread apart for a child to force its way through or the wires may provide a 'ladder' for it to climb over the rail.

TABLE 9 - Handrail Heights

Bridge Design Code -	Min rail	Preferred rail height
Pedestrian Barrier	1.1m	1.1m
Cyclist Barrier	1.3m	1.3m
AS 1428.2 Design for Access & Mobility	Min rail	Preferred rail height
Handrails at walkways ramps & landings	0.87 m	1.0 m
Building Code of Australia	Min rail	Preferred rail height
for balconies between 1 & 3 m above ground. (125 mm max gap)	1.0 m	
for balconies less than 1 m	no rail required	

The Bridge Design Code specifies a maximum baluster gap of 130mm which assumes very small children (pre-school age) are under supervision. The BCA requires a similar gap (125 mm) based on the same design child but with the presumption that the consequences of falling 1 to 3 metres are not major. (For higher fall heights (i.e. greater than 3 m), more stringent barriers may be required but these are beyond the scope of this guide).

It is implied that if small children are in public spaces where boardwalks are installed, there will be parental supervision at a level greater than required on a play structure. Note that none of these systems reviewed here meet the standards for swimming pool fencing where, amongst other things, maximum baluster gaps of 100mm are specified.

For the decking systems in this report, the desirable minimum height to ground is 600mm. Use of a low profile system (bed log) can reduce this to within 400mm of the ground. For lower heights use timber mats or chain mats using Durability 1 timbers.

An attempt has been made here to give some rationale to the provision of safety while presenting a minimum of intrusion into the environment. This recognises the difference between the functions of boardwalks on the one hand and bridges and building structures on the other. While suggestions are made here on edge treatments, designers must make their own assessment of the balance between risk and the intrusiveness of the railing systems.



**Fig 15** Stainless steel wire as barrier infill.

Stainless steel wire running horizontally at about 100mm spacing is often used in hazard levels E & F (*Table 10*) together with a solid top rail. While this barrier is not as effective as close balusters, it does allow for some control of small children while not being as visually intrusive. Droppers can be used to prevent spreading apart of the wires.

In many situations the cost of the railings may be equivalent to increasing the deck width by 30%. That is, making a wide walkway may feel just as safe as a narrow one with railings, as the user can keep away from the unguarded edges (*this assumes a rail is not mandatory*). If much of the deck surface can be kept low to the ground, a large proportion of the boardwalk may not need rails.

### **Handrail Height**

AustRoads prefers pedestrian barriers 1.1m high and cycling barriers 1.3m; but these rules are applied to the whole spectrum of road bridges where perhaps as many as 99% would have fall heights greater than 3m. Since boardwalks in this discussion are limited to 3m high above the finished ground, risk analysis suggests that lower barriers could be acceptable and this is supported in Walking Track Infrastructure.

Boardwalks are, in the main, continuous viewing platforms. Accordingly uninterrupted sight lines are desirable. Based on a line of sight 13° below the horizontal (*comfortable range*) and a practical distance away from the rail (*based on the user*), a standing adult requires a rail below 1.4m while a wheelchair based adult requires a rail below 0.85m so that the view is not impaired. Note that it is often the case in wetlands that the points of interest are below even this angle. (*The intent of portion of the BCA seems to permit a low rail (0.7m) if there is one metre of deck outside the rail to act as a catch platform but this is done infrequently.*)

Where the fall height is more than one metre, 870mm high rails meet practical requirements including AS 1428.1 & BCA for ramps and landings but not the requirements of the BCA for balconies or AustRoads for general bridges. Increasing the rail to 1100mm meets all requirements except for bicycles, but impairs visibility. A rail height of 1300mm meets the minimum safety requirements of all users but the barrier may be visually unacceptable.

TABLE 10 - SUGGESTED EDGE RESTRAINTS - WALKING TRACKS

RISK LEVEL	Maximum Full Height M	Fall on to	$h_{eff}$ m Effective Fall Height from AS 2156.2	Edge Treatment	Infrequent Users	Application / Comments
A	0.6	grass, swamp, water < 0.9 m deep including tidal water	0.1	none	disabled, poor sighted, cyclists, crowds	Class 2 - Track
B	1.0		0.5	kerb	crowds, poor sighted	Class 1 - Track
C	1.2		0.7	top rail with kerb (type D barrier)		Class 1 - Track
D	1.5		1.0	high kerb	disabled, poor sighted, cyclists, crowds, children	golf courses incl. golf cars
E	1.8		1.3	top & intermediate rail (type C barrier)	disabled, poor sighted, crowds, children	Class 3 - Track, Partial barrier - cyclists
F	3.0	hazardous surfaces	6.0	top rail & balusters		Class 1 - Track debris problem if submerged during flood?

Regardless of the above, rails may be needed as resting areas for the disabled and for both sides of ramps.

Table 11 - Handrail Heights Summary

Application	Fall height			
	< 1 m		> 1 - 3 m <	
	Infrequent disabled	Disabled users	Balconies BCA	Bicycles AustRoads
Handrail Height m	Nil required	0.87	1	1.3

### Cycling and Disabled Handrail Requirements

Cyclists require a rail that is continuous and relatively easy to grab with a support that does not catch pedals or handlebars. The disabled also require a continuous rail that does not break the hand hold when assistance is required in negotiating ramps. They need a post/kerb system that does not trap wheelchair footplates or leading wheels. AS 1428.1 requires that grab rails be no larger than 50 mm diameter so that a hand may comfortably grip the rail. All these requirements lean towards a metal rail 50 OD although there has been a trend recently to large diameter (75-100 mm) rails to steady cyclists at stopping points.

### Handrail Systems

After considering the economics and practicalities of the whole boardwalk system, including the foundations, 3m is the most appropriate span for each element in the structure. For bridge aesthetics, a general principle is that the handrail post supports should occur at pier positions. As many boardwalks meander, a handrail post must be provided at the change of direction: the pier position. Also the pier provides the opportunity for a more rigid connection to the handrail post to ensure the railing system is rigid. 3m is a large span for a handrail, so unless an intermediate support is introduced, sizes larger than domestic rails are used.

### **Sawn Post System-minor**

Sawn handrail posts can be placed at 2m to 2.5m centres with rails cantilevering both ends to provide full 3m span coverage. While the components of this system are smaller, virtually double the number of posts are required.

#### **Advantages:**

- components are smaller
- connections are simple requiring little skill
- accommodates changes of direction

#### **Disadvantages:**

- posts are bolted to small joists (away from the pier) and are dependent on joist torsional resistance for stiffness
- With large changes of direction (20° or so) the use of horizontal wire infills is not practical as the wire, running from post to post, truncates the corner too much.
- post position doesn't comply with the old axiom: posts must be at piers. (Of course this comment is only relevant if the boardwalk is viewed from afar.)

When the handrails are not sufficiently stiff, an outrigger may have to be employed. This can look clumsy and may end up being more expensive than the Major System described below.

### **Sawn Post System-major**

Handrail posts can be installed at pier positions if heavier rails are used. It is difficult to detail rail connections for walks that meander when using this system so it is best to limit changes of direction to less than 6° per span (less than 0.3m change in 3m span). While it is possible to have the rail continuous over the top of the post this practice does emphasize minor misalignments to the eye. To avoid this, allow posts to protrude above the rail, breaking the line of sight.

#### **Advantages:**

- posts are fastened at piers enabling a variety of fixing ensuring a stiff rail.
- horizontal wire infills can be used
- post position looks logical.

#### **Disadvantages:**

- components are heavier as they are more heavily loaded
- connections require skill
- accommodates minor changes of direction only.



Fig 16 Post projection breaks line of the rail

### **Round Post System**

The round post system allows complete freedom of alignment. It fixes at the pier where rigidity may be achieved by several means. The posts protrude above the rail to break the unnatural look of an unbroken horizontal line and conceal rail misalignment. This system is recommended for the handrail support for most boardwalks.



Fig 17 Round handrail post system



Fig 18 Round handrail post system - router jig

## Pine Posts

Advantages of treated pine posts:

- lighter
- available as parallel sided so that diameter is consistent
- less shrinkage
- compatible with concrete backfill in potted post construction
- can be floated in without additional buoyancy in wetland environments

## Hardwood Posts

Disadvantages of treated hardwood posts:

- heavier especially when mechanical handling not an option
- not available in consistent diameters (problems with detailing, bolt lengths etc)
- must use compacted gravel backfill and this presents problems with temporary bracing restricting access in potted post construction.

Advantages of hardwood posts:

- double treated hardwood (CCA with PEC) is more effective than pine for marine immersion (but pine poles may be readily sleeved to resist this attack).

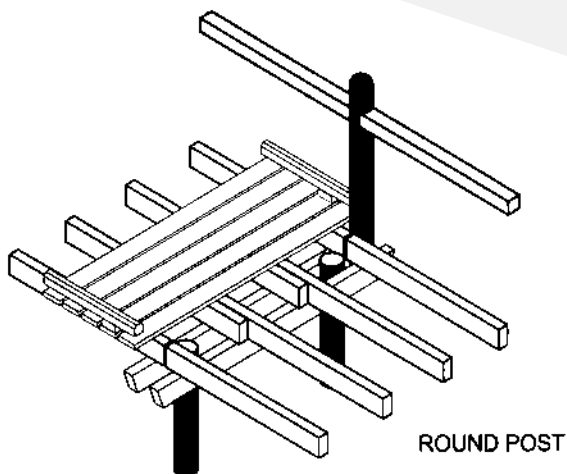

Fig 19 Handrailing Systems

## Kerbs

Kerbs are installed to define the decking edge and give some restraint to wheeled vehicles, the disabled and the poorly sighted. While kerbs on timber decked bridges are often used to restrain decking from rattling, this is not the case with boardwalks.

Kerbs have the following disadvantages:

- restrict the freeform nature of the deck constraining it to straight chords (kerbs curved in plan are not easy to form from timber).
- cost
- increase flood forces
- tend to accumulate leaf litter
- cause deterioration of decking beneath due to trapped moisture.

Spacing the kerb above the decking does allow a measure of self cleaning as it allows the wind to blow much of the litter off the deck as well as reducing entrapment of moisture.



Fig 20 Low boardwalk without edge restraint generally but rails introduced locally to prevent access to fragile marine couch.

## Curves

Usually the timber handrail systems consist of straight lengths forming a series of chords to the horizontal curve. While an unprotected snaking deck edge can be quite graceful, it is not generally practical to make curved handrails or kerbs in timber. Where this is a must, galvanized steel or aluminium hollow sections can be rolled to the specified radius.

## Structural Systems

Various structural systems are explored and recommendations made.

### Deck Types

#### Decking Longevity

The walking surface of the deck degrades due to:

- Ultra violet light
- Mechanical damage (turning or braking vehicles)
- Shrinkage cracks
- Fastener initiated splitting
- Wetting and drying
- Biological decay (rot)

The hot tropics is a most aggressive environment with high UV causing fibre de-bonding, high temperature increasing biological attack and the frequent wetting and drying giving rise to splitting. Conversely colder climates, those with a dense tree canopy providing shade (*but without problem leaf litter*) and a more constant timber moisture, increase the decking life.

Deckwood is particularly effective in resisting degradation and has a sawn surface uppermost as this results in superior longevity and is less slippery when wet. A reeded finish (*requires more maintenance*) can be ordered for steep ramps or for very slippery areas *e.g. marina or pool decks* where safety is paramount. (*but at the expense of longevity*).

While an opaque paint system could assist in promoting decking life, there are problems with:

- slippery wet surface (requiring an additive to restore friction)
- cost of re-application
- short life due to mechanical wear
- short life due to horizontal surface
- appearance compared with natural timber finishes

Light coloured stains may overcome most of these problems.

Preservative oils like CN (copper naphthanate) Oil are more appropriate in many situations and are the recommended system and should be applied all round. Outdoor Structures Australia can undertake this oil application prior to delivery so that the public access withholding time is shortened. Regular application of the oil will lead to a longer decking life. Traffic

should be kept off for several weeks until the oil has penetrated so that the surface is not slippery. Tanacoat can be used where a less soiling finish is needed.

CN Emulsion is effective in retarding moisture loss from the end grain of the decking and reduces end splits. It also reinstates the enveloping preservative to the site-trimmed decking.



Fig 21 CN Emulsion on cut end

In virtually all situations, except sometimes for the handrail, a sawn hardwood surface is preferred.

Handrails are sanded and finished to present a clean surface, free of splinters.

### Decking lay up

Almost invariably decking is laid across the short direction of the deck so that joints at decking ends are eliminated. This also produces better utilization of timber as shorts are used. This means an isolated surface defect in a long piece of timber can be cut out, often leaving two useful defect-free pieces.



Fig 22 Staggering of plank joints in wide sections of decks is facilitated by paired joists

While a superior ride for wheeled vehicles is experienced using running planks (decking parallel to the direction of travel) AS 1428 and Bicycles - AustRoads require that for decks that carry cyclists, wheelchairs and invalids, decking is to be laid perpendicular to the predominant direction of travel. This is mainly because of problems trapping thin tyres. Further, the final gap between planks should not be greater than 13 mm. For golf cars and similar, vibration and noise may be minimized by skewing the direction of the decking by five degrees to the direction of travel. Then both wheels (on one axle) do not roll onto the same decking plank simultaneously.

## Economy

Timber is sold in length increments of 0.3 m. While timber can be supplied docked accurately to the deck width ( $\pm 5$  mm) by the sawmill, inevitably the ends need to be trimmed to a neat line on site so accurate predocking is often not worthwhile. Further, timber is supplied somewhat over-length to allow site trimming and the removal of any end splits. To speed up the installation process, it is suggested that the finished deck width be 0.1 m under the nominal timber length. This allows an additional 50 mm tolerance on position (each end), especially for alignments that meander (as opposed to straight runs) as it can be difficult to judge the exact (trimmed) edge until a substantial area of deck has been laid.

This results in preferred finished decking widths of 1.4, 1.7, 2.0, 2.6, 2.9 & 3.5 m used in this publication.

These dimensions have been used in arriving at the recommended deck widths. The clear distance between the kerbs or rails is somewhat less than this deck dimension depending on the system chosen. The Deckwood Selection Guide contains more data on the design and use of the decking material.

## Deck Types

### Low Profile Deck

For narrow decks (1.4 m wide) a Low Profile system is possible. This enables the deck to skim over the ground often eliminating handrailing and even, in some instances, the kerb. The headstock is not needed but the system requires a thicker deck (90x45 min decking size) as only two joists are used. With the low ground clearance, post sizes could be reduced to 125mm diameter as lateral stiffness is less of a problem. The system also facilitates incorporation of occasional steps and substantial changes of direction.

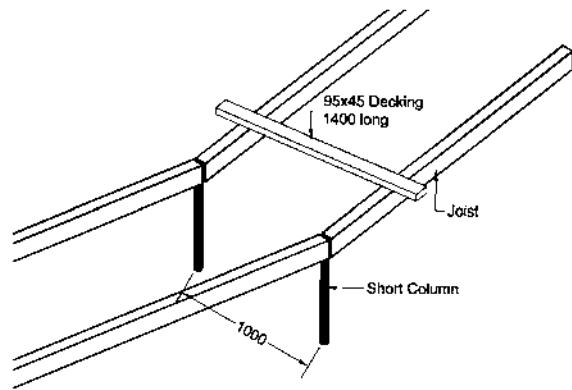

Fig 23 Low profile deck system

### Normal Deck

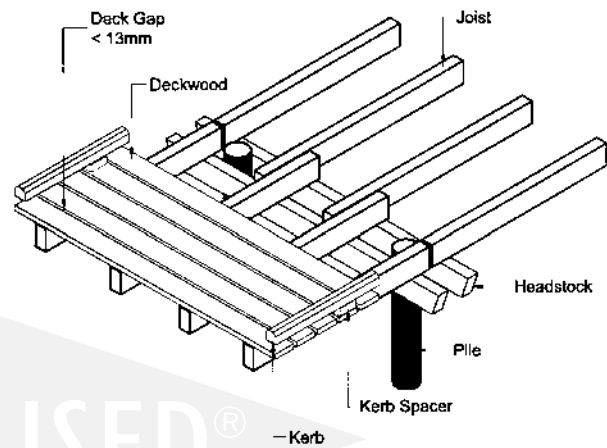

Fig 24 Normal deck system.

### Decking

Research on external timber structures indicates that rain soaked wood only becomes a durability concern when it cannot dry rapidly. Obviously periodic removal of leaf litter facilitates drying as does generous spacing of decking.

Fig 25 shows Outdoor Structures Australia's patented decking profile. The taper towards the bottom acts like a self cleaning grate assisting in removal of leaves as well as encouraging air drying at the joist-decking interface. Making the top edge pencil rounded rather than arised reduces corner splinters and makes the decking easier to handle. The wider sections have a anti-cupping groove on the bottom side.

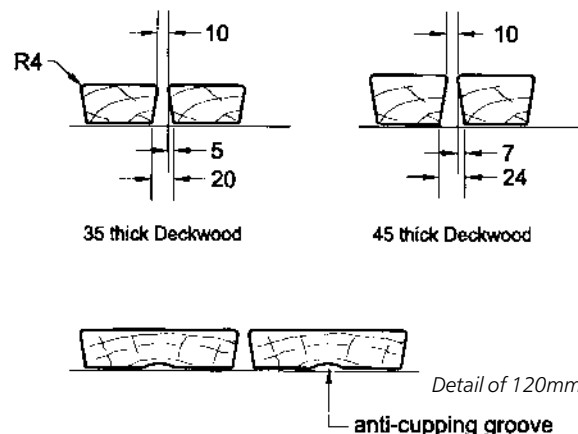

Fig 25 Simplified drawings of OSA's Patented Deckwood profile

Note that structural layouts for systems without handrails can be different for those with handrails because of the requirements of fixing the stanchions (*handrail posts*).

The charm of many boardwalks is that they can easily wind around obstructions. Systems are required to achieve these changes of direction of the deck in a systematic way. The factory produced tapered decking simply allows shaped decking to fan around corners and is the easiest system to use. The small end is limited to 60mm to allow fastening. Lengths are usually 300mm longer than the adjacent boards due to skewness. The number of tapers required to negotiate a change of direction depends on the decking width but require roughly between 10 to 20 tapers per 10° change of direction.

Mitred decking patterns suit more formal layouts and abrupt changes of direction but take more care in installation and maintenance. A variation to mitred decking, using a radial member between changes in direction, reduces the carpentry skills required as it can conceal mitres that do not neatly bisect the change in direction (*due to errors in substructure orientation*) and reduces the need to neatly match the mitred members.

When the walk slinks from side to side and back again, decking can be more economically laid without change of direction by merely skewing up to 30° as shown in Fig 26 provided maximum decking spans are not exceeded.

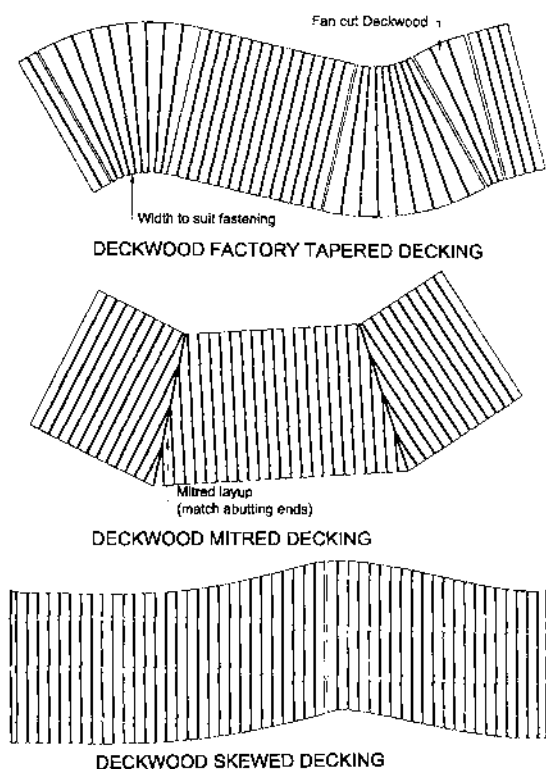

Fig 26 Decking patterns for changing

## Construction Requirements

Outdoor Structures Australia supplies detailed illustrated instructions for the installation of boardwalks with every kit delivered. These included notes on:

- environmental issues
- application of preservatives including safety aspects
- working with hardwood
- installation of fasteners
- decking installation
- handrailing techniques

Outdoor Structures Australia supplies a priced materials schedule for each job and arranges the staging of deliveries to suit work progress.

Additionally extra fabrication services can be provided to facilitate installation and reduce time on site.

These can include:

- pre-oiling decking and joists
- predocking to size
- prefabrication of decking modules
- balustrade systems
- epoxy coating galvanized items for increased life
- pencil rounding kerbs and posts
- various shaped handrails
- pre-sanding handrails
- end detailing to post tops

Frequently equipment and hardware are supplied. This ensures that otherwise difficult to locate items are delivered in the one delivery making it virtually a complete kit.

These can include:

- router guide for easy, precise handrail fixing
- bolts, washers & other hardware in heavy hot dipped galvanized finish as well as stainless steel.
- baseplates and bracing
- stainless steel rigging for handrail infills
- preservatives, paints, stains and coatings

Outdoor Structures Australia has a team of Approved Installers who are experienced in all facets of boardwalk construction.



Fig 27 A mitred deck surrounding a specimen tree requires good attention to setting out and experience to achieve a neat result.

## Design & Construction with Hardwood

### General

Outdoor Structures Australia uses Australian open forest dense hardwoods (not rainforest species) exclusively as they are excellent construction materials and exhibit superior resistance to abuse, decay and vandalism. For those unfamiliar with hardwood, a little time spent in understanding the material in both detailing and construction will pay off with a handsome, long lasting structure. In the following discussion hardwood, supplied by Outdoor Structures Australia, is compared with timbers possibly more familiar to the reader. The properties discussed are those that are relevant to outdoor structures.

### Durability

Wood durability has been traditionally measured by graveyard performance of stakes in a hazardous environment. Recent work has developed ratings for timber used above ground and this preliminary work has been included in Table 12.

Table 12 TRUEWOOD DURABILITY

Species	Durability		Termite Class
	In ground	as superstructure	
Iron Bark *	1	1	1
Grey Gum	1	1	1
Tallowwood *	1	1	1
Gympie Messmate	1	1	1
Cypress Pine	2	1	2
Spotted Gum **	2	1	2
Blackbutt, New England	2	2	2
Kwila (Merbau)	3	1	3
Jarra	3	2	3
Western red cedar	3	2	3
Brush Box	4	3	4
Oregon (Douglas Fir)	4	4	4

\*\* predominant species used for Deckwood

\* additional species used for Deckwood in limited quantities

A list of appropriate species in Table 13 is sourced from bridge construction authorities. While for most timber road bridges an asphalt wearing surface is placed over the timber deck, the listed species are still considered appropriate to decks with running planks (no deck wearing surface).

TABLE 13 TRADITIONAL SPECIES USED IN BRIDGE CONSTRUCTION

Bridge Components	Suitable Species	
	Hot tropics	Additional species - other regions
Piles Struts & Fenders	Ironbark	
Girders, corbels & kerbs	Ironbark, Spotted Gum Gympie Messmate	Grey Gum
Headstocks	Ironbark Gympie Messmate	Tallowwood, Grey Gum Blackbutt, Spotted Gum
Wales, braces & handrails	Ironbark, Spotted Gum Gympie Messmate	Tallowwood, Grey Gum Blackbutt
Decking	Ironbark, Blackbutt Gympie Messmate	Tallowwood, Grey Gum Spotted Gum

## Strength

Table 14 shows the superior strength (*more than double*) and stiffness (*almost double*) of hardwood relative to softwoods. Toughness is the capacity to resist abuse and impact. While the Janka figures shown here relate to seasoned product, they indicate relative resistance to indentation of unseasoned decks.

**TABLE 14 STRENGTH PROPERTIES**

Species	Stiffness	Bending	Bending	Toughness	Janka
	E MPa	<i>WSD</i> F'b MPa	<i>LSD</i> F'b MPa		Hardness
Iron Bark *	16000	22	65	H	16.3
Spotted Gum **	14000	17	50	H	10.1
Jarrah	10500	11	33	L	8.5
Oregon (Douglas Fir)	7900	6.9	20	L	3.0
Cypress Pine	6900	5.5	16	L	6.1
Radiata Pine	6900	5.5	16	M	3.3

*Toughness nomenclature: -H=high, M=medium, L=low*

## Weight

Table 15 shows the range of unseasoned densities for various timbers. While the range of densities is large, the actual range of component mass is significantly less. Spotted gum 150x75 has been adopted as a standard for comparison purposes and the depth (D stiffness) of the common grades of the other species has been computed so that they all exhibit the same stiffness, as this generally governs design.

For comparison purposes, D bending shows the relative masses of components sized for the same bending strength.

**TABLE 15 TIMBER COMPONENTS MASS (unseasoned)**

Species	Timber density	Same stiffness		Same Strength	
		D stiffness	kg/m	D bending	kg/m
Iron Bark *	kg/m <sup>3</sup> 1250	143	13.4	132	12.4
Spotted Gum **	1200	150	13.5	150	13.5
Jarrah	1100	164	13.6	185	15.4
Cypress Pine	850	190	12.1	264	16.8
Radiata Pine	800	190	11.4	264	15.8
Oregon (Douglas Fir)	710	182	9.7	235	12.5

It should be noted that a standard 3.3 m length of 150x75 joist weighs less than 45 kg, an easy lift for two.

## Forest Resource

It is important that the forest resource is milled and used as efficiently as possible to minimize cost and to maximize the number of structures that can come from each tree. As the timber used for decking has to be substantially defect free, the choice of smaller sections and lengths increases the amount of decking recovered from a log. Hence, when there is no overriding reason, decking should be 35x70 with a preferred maximum length of 3.6 metres. Having said that, 35x120 has proven to be the most popular size and is more freely available.

The forest is used even more efficiently if the life of the structure can be increased, as well as locking up carbon so that the greenhouse gas (when the timber decays) is delayed. The longevity of the structure can

be ensured by:

- species choice
- grading decking free of defects that otherwise could lead to premature decay
- preservative treatment of the sapwood
- constructing the deck to Outdoor Structures Australia's good practice documentation
- finishing & maintenance practice as per Outdoor Structures Australia's recommendations.
- Outdoor Structures Australia's unique profiles designed to promote longevity.

Where there are concerns about log sourcing and forestry practice, a certificate can be issued to the effect that the timber was obtained from State Forests, harvested and managed on a sustained yield basis. In order that the log's origin can be tracked through its processing, substantial notice has to be given so that it can be tagged before cutting.

**TABLE 16 - FIRE INDICES**

Species	Early Fire Index Spread of flame (0-10)	Charring rate mm/min
Spotted Gum **	3	0.45
Iron Bark *	5	0.45
Jarrah	6	0.45
Cypress Pine	8	0.55
Radiata Pine	8	0.65
Oregon (Douglas Fir)	9	0.65
Western Red Cedar	10	1.05

*A low EFI means that the fire spreads less quickly.*

While most timbers ignite with about the same degree of difficulty, flame spreads more slowly on dense hardwood allowing more time to extinguish it. It also chars more slowly so it often has a better chance of survival than softwood.

## Fire

Obviously with any timber structure, fire can be a problem. The fire source can be forest or grass fires or sheer vandalism. Good maintenance practices can eliminate a great deal of the litter that causes much of the problem. Removal of leaf litter also aids in the prevention of dry rot. Spacing the decking timber and raising the kerb facilitates a measure of self cleaning while removal or cutting of adjacent grass reduces the fuel available. Where CCA treated support posts are particularly vulnerable, the timber can be painted with a paint that reduces the spread of flame. This lessens the likelihood of the structure catching fire from below. Normally fire is less of a problem with walks in marine wetlands.

## Preservatives

No matter what the durability of the truewood, the sapwood of all species is not durable. In order to utilise more fully the forest harvest, the sapwood has to be preservative treated when used in exposed structures. Outdoor Structures Australia was the first company in Australia to adopt a new generation (copper azole) sapwood preservative. While being as effective as CCA in above ground use, this product still provides highly effective protection against decay and insect attack but it is free both of chrome and arsenic.

The normal procedures for handling and working CCA treated hardwood apply to Tanalith E treated components and details of these are sent with every boardwalk delivery. In particular, goggles, masks and gloves are required during cutting the timber. Offcut timber should not be burnt but disposed of at a landfill site. In environmentally sensitive areas, heavy poly tarps can be used on the ground in the fabrication area. At completion of each day's operations the material can be gathered up and offcuts and sawdust easily tipped into a dumpster for suitable disposal. Offcuts further along the site should be placed into containers as the work progresses for future collection and disposal, leaving the site in an unsullied condition.

CN (Copper Napthanate) Emulsion is applied to all housings, end grain and joints including the joist-deck interface. Detailed instructions for this are included in the kit. It is like a green grease that easily fouls clothing and hands. Any excess that is likely to be in areas handled by the public should be removed at completion of the job.

CN Oil should be used on all timber (except the railing system) to retard moisture movement, seal the surface against water ingress and prevent fungal development. The resulting surface is slippery for some weeks (depending on weather and climate) and so the public should be prohibited while the hazard exists. Do not use linseed oil as it encourages fungal development.

Surfaces that are frequently handled, should not be oiled with CN Oil or Creosote but painted with a fungal resisting stain or paint. Of their very nature, paints and stains need more attention and maintenance than oiled surfaces. Only light colours should be used as dark colours increase the timber temperature; promoting fungal growth and premature breakdown of the finishing system.

Outdoor Structures Australia recommends Tanacoat for maintenance applications for decking as it is an economic and effective water repellent and UV blocker. It is a penetrating oil that reduces tracking it onto other surfaces and soiling of clothing that can be a problem with CN Oil.

Outdoor Structures Australia can supply decking pre-oiled. This results in:

- faster construction
- the public being allowed access immediately as the oil has had time to penetrate
- more uniform product
- less messy handling on site
- fewer interruptions due to wet weather.

## Shrinkage

All timber shrinks across the grain as wood loses moisture after milling. Different species shrink various amounts as shown in the accompanying table.

**TABLE 17 Tangential Shrinkage from unseasoned to seasoned**

Species	%
Brush Box	9.7
Ironbark, grey	7.5
Jarrah	7.4
Spotted Gum	6.1
Radiata Pine	5.1
Douglas Fir	4
Cypress Pine	2.5

### Notes

*Actual shrinkage will be less than that shown as timber will not completely season in a weather exposed environment. Also radial shrinkage is almost half that of the tangential direction and so the shrinkage depends very much on the orientation of the sawn piece to the original log.*

Spotted gum has about 50% more shrinkage compared with Douglas Fir but the reality is that as joists and headstocks in spotted gum are about 25% smaller the shrinkage that a joint has to accommodate is not as great.

The consequences of shrinkage should be considered:

- at joints
- in providing sufficient thread length to allow tightening of bolts as timber seasons
- when different thickness of timber may make an abrupt misalignment of the decking
- when adjacent to a fixed level e.g. concrete path

Details of initial decking gaps at fixing time for various environments are given in the Deckwood Selection Guide.

If water passes over unpainted hardwood it can produce a brown stain on the surfaces below. This is more likely to occur when the timber is freshly sawn but will continue to a lesser extent after it is seasoned or weathered. There are some cleaning agents that will remove the stain, but discolouring will reoccur unless water is excluded. Flashings or roofing can be used to direct water away from any surfaces to be protected or an opaque paint system can be applied to all the hardwood surfaces including all housings and notchings. Most boardwalks are located in a situation where this is not a problem.



**Fig 28 A wide section of deck split into two sections. Note the paired joists. Decking ends are about to be trimmed and a banding plank installed before continuing with the deck.**

### **Storage**

When properly used, hardwood is one of the toughest, most serviceable and most easily handled of all building materials, but like other structural members, it can be seriously damaged by mishandling, especially careless or improper exposure to wetting and drying.

Hardwood is more easily cut and drilled when it is unseasoned so it makes sense to retard drying while in storage on site. The best means is to block stack the timber level, at least 150 mm above the ground. Any vegetation on the ground should be scraped away or covered with an impervious sheet. The whole of the stack, including the ends, should also be covered with an impervious sheet, spaced so that the timber is protected from the sun's heat and to retard drying. Proper stripping of the timber should be undertaken so that the timber cannot twist or distort as otherwise this could make it very difficult to build into the works later.

It is recommended that all timber ends be coated with petroleum jelly or a wax coating to control end splitting that is a direct result of rapid drying. When the timber is subsequently incorporated into the structure, the freshly trimmed ends are coated with CN Emulsion which also retards drying as well as preserving.

Completed sections of the boardwalk, especially widenings, can make excellent storage and fabrication areas provided that the mass of timber being supported is no worse than a solid section 300 mm high.

### **Working**

Hardwood is more easily worked while it is unseasoned. For this reason it is best to keep it from drying out whilst in storage. (Refer to the section on Storage). In order to retain the treatment envelope intact, any extensive working of the timber should be undertaken at Outdoor Structures Australia before treatment. This results in a more uniform product, faster construction and less waste for disposal.

While spade bits are efficient at boring through hardwood they should only be used when mounted on a drill stand as otherwise the bored hole may not be straight. Wood bits (scotch pattern augers) easily produce straight holes and can be used in electric drills for 12 mm holes (and larger) but pneumatic drills are preferred for safety (especially over water), superior torque and stalling does not result in burnout.

Edges of all timber should be chamfered to resist splinter development and as an aid to safe handling. Deckwood is supplied standard with pencilled top edges. More specific details of construction are contained in Outdoor Structures Australia's Construction Guide that is supplied with every kit.

## Deck System

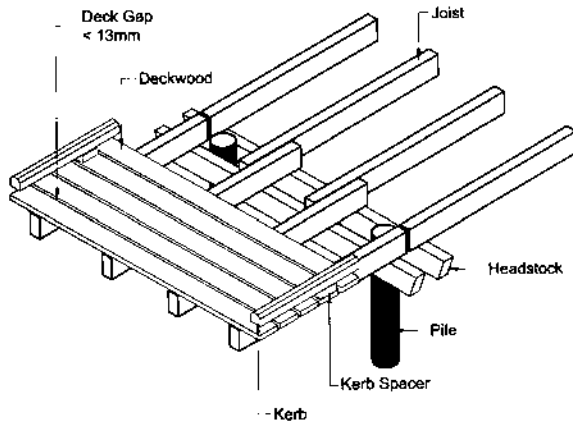

Fig 29 Normal Deck System

The normal deck system shown in Fig 29 facilitates change of direction at each pile/post end. Internal joists can overlap to provide deck fixing remote from the joist ends, this eliminates having to trim joists to length. Edge joists need to butt up so that the external appearance is uniform and to ease handrail installation. The double headstock distributes the load into the pile so that, in many situations, a single bolt is all that is required. Headstocks project beyond piles to ensure development of full bolt strength as well as a fixing for the handrail post, if required. Decking gaps depend on the users and Deckwood™ shrinkage. Guidance on shrinkage and gaps is given in the Deckwood Selection Guide.

## Loads

While timber members for private decks may be sized adequately by using domestic framing manuals, this publication is intended for boardwalks completely weather exposed and with public access. The loadings on public precincts are much heavier than domestic loadings. The client or approving authority may require it to comply with the requirements for building (BCA), bridging (AustRoads) or walking tracks. The former is likely if it constitutes an extension to a building while Austroads may claim authority if it is within a declared road reserve. Otherwise if the expectations of pedestrians are low (e.g. bushwalkers) it may be designed as a walking track structure which acknowledges the likelihood of lower loads.

The BCA implies less loading than the bridge code unless there is a crowd panic situation and that scenario (5 kPa) is improbable unless a boardwalk has handrails on both sides to contain a crowd. The BCA allows more variety in handrailing depending on the consequences of falling.

As would be expected, the bridge code demands a higher design load and applies substantial railing requirements, as falling from a typical bridge could always be imagined as life threatening. All Codes are in a Limits State Design (LSD) format. A case has been made for application of exposure reduction factors (N) to account for some strength and stiffness loss in-service. Recent testing of existing road bridges has confirmed this does occur. A reduction in both bending strength and stiffness has been applied in the tabulations in this Guide.

Boardwalks do not usually form part of an essential transport link and so temporary closure for maintenance or damage repair is not as disruptive as it may be for conventional pedestrian or cycle bridges providing access to work or school. Also access for pedestrians on temporary planking may be possible during repair.

Source Document & Sections	Uniformly Distributed	Concentrated Live Load
<b>AS 1170.1</b>		
Landings, terraces & plazas leading from ground level - restricted to pedestrian traffic	4.0 kPa	4.5 kN
Wheeled trolleys	5.0 kPa	4.5 kN
Sect 1.1 - general for housing & NAFI Timber Framed Housing Design - Methodology & Performance Criteria		1.8 kN on 350 mm <sup>2</sup> with a serviceability limit of 1.7 mm for a 1 kN point load on a single board
<b>AUSTROADS 2004 Bridge Design Spec. (Limits States)</b>		
Loaded element	5.0 kPa	
<b>Walking tracks Class 3 &amp; 4 AS2156.2</b>		
Viewing platform	4.0 kPa	1.4 kN over
Boardwalk	3.0 kPa	75mm x 75mm
<b>Walking tracks Class 5 AS2156.2</b>		
Viewing platform	3.0 kPa	1.4 kN over
Boardwalk	2.0 kPa	75mm x 75mm

Table 18 - Live Loads on Deck

## Maintenance/Construction Loads

The 4.5 kN concentrated load is equivalent to an infrequent, slow-moving vehicle with a maximum gross mass of 1.5 tonnes. This allows for limited construction and maintenance traffic distributed into four pneumatic tyres each spreading the load over 150 mm x 150 mm area.

## Golf Cars & Equivalent

A deck designed for the 4.5 kN load above also allows for the continuous use of low speed golf cars with a gross vehicle weight of 8 kN (500 kg kerb weight plus two occupants) with 2.5 kN wheel loads concentrated

over 100 mm x 100 mm. Skewing the deck planks by 5° to the direction of travel and the use of 120 mm minimum width decking should be used to reduce rattles and improve ride. This is facilitated by skewing the abutments and laying the decking parallel to the abutment.

### Tractors & Other Equipment

Golf course and park maintenance equipment vary greatly in mass. Provided that they are no heavier than golf cars their passage is allowed; otherwise specific design is required (and the requirements may change with changing equipment). [AustRoads specify a 30 kN concentrated wheel load for tractors crossing pedestrian bridges. This would increase the decking cost considerably and is outside the scope of this report].



**Fig 30** The load capacities of All Terrain Vehicles are increasing to carry all manner of loads.

For this reason Load Limits need to be plainly displayed.

Physical barriers and load limits may need to be posted on vehicle-accessible boardwalks to restrict traffic. Note that other infrequent traffic may have to be catered for e.g. ambulance, fire and refuse trucks. Guidance for these is not given in this report.

### Animal Loads

Widely spaced boards resemble stock grids and are not compatible with livestock. As well, livestock (horses included) loadings can be considerable and would unduly govern decking design and should be excluded from these structures. Prohibition notices should be posted for the benefit of horse riders in areas where this use is a possibility. It should also be remembered that the coefficient of friction between steel horse shoes and wet timber is very low.

### Design Loads

The Concentrated Live Load of 4.5 kN for light wheeled vehicles normally governs the decking plank design.

In the tabulations that follow, 5 kPa has been used as the conservative design Live Load for decking and joists. The piling may be designed on a UDL Live Load of 4 kPa based on deck area assuming that the peak (5 kPa) loading is not distributed uniformly over the complete span (this may not be valid with lookouts).

The Serviceability Uniformly Distributed Loads usually governs joist design. A stiffer deck is necessary for golf cars to improve ride and reduce rattle as these decks do not have the benefit of running planks or a deck wearing surface as do conventional timber vehicular bridges.

### Decking Design

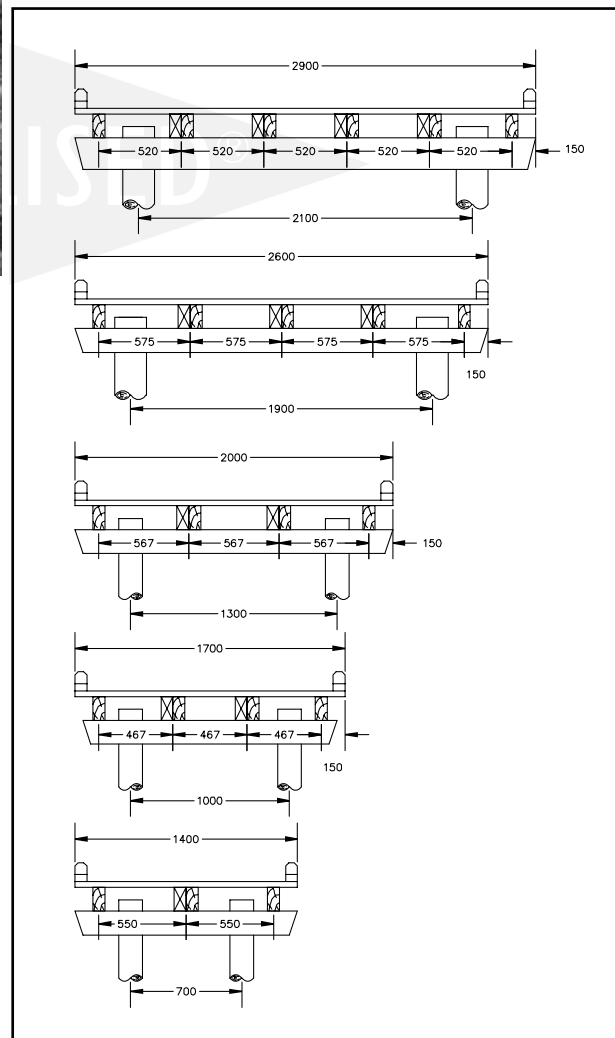

**Fig 31** Typical Framing Layout for Pedestrian Boardwalks 35x120 decking is assumed - railings not shown. There may need to be more joists when narrower boards are used.

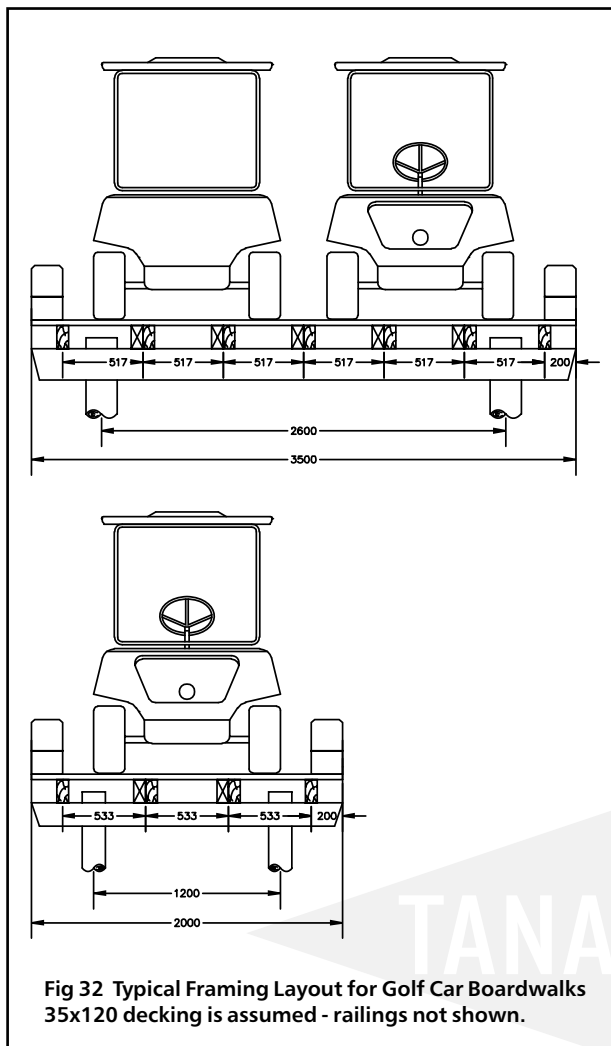

## Concentrated Loads on Decking

### Point Load

The intensive concentrated load of 1.8 kN over 350 mm<sup>2</sup> produces a compression perpendicular to grain of 5.1 MPa (5.2 MPa is permissible). This means that less dense timbers (S3 to S7) would not meet this criterion. i.e. Douglas fir and Slash pine would be overloaded 100%, hem-fir, meranti, and hoop pine would be even worse, most likely suffering visible damage.

### Concentrated Load

An equivalent concentrated load per plank in Table 19 has been derived from distributing 4.5 kN over a 150 mm square.

**TABLE 19 - CONCENTRATED 4.5 kN LOAD DISTRIBUTED INTO DECKING**

Deckwood width mm	Effective conc load/plank kN
70	2.5
95	3.2
120	4.0
145	4.5

For frequent wheeled loads Deckwood needs to be at least 120 mm wide to produce a smoother ride and reduce decking rattle.

For a wheel load applied at the cantilever edge of the decking assume that there is a kerb at least 75 mm wide, so the load is effectively concentrated 150 mm from the nominal edge *i.e. neglect the situation of a vehicle mounting the kerb as this is a crash situation, not a design situation.*

**Table 20 Deck Design Cases (2 span continuous one span loaded only)**

Live Load Case	Load	Serviceability limit
Uniformly distributed	5 kPa	span/360
Concentrated	4.5 kN (refer table 21)	span/180
Concentrated (pedestrian & cycle)	1 kN	1.7 mm
Concentrated (golf car)	2.5 kN	1.7 mm

The uniformly distributed load is easily carried. The spans are limited by serviceability under concentrated loads including the relative deflection between adjacent deck planks.

**Table 21 Maximum Decking Span**

Deckwood size	Pedestrians		Cycleways & Golf cars
	Normal Profile	Reeded Profile	Normal Profile
35x70	530	450	N/A
35x95	600	510	N/A
35x120	610	520	560
35x145	610	520	570
45x70	710	600	N/A
45x95	780	660	N/A
45x120	860	730	780
45x145	890	750	820

Spans apply to decking continuous over two equal spans minimum. Where this is not so, reduce spans to 85% of those tabulated.

### Decking Fixings

Hardwood used in Deckwood™ is very dense so it belongs to the strongest joint group. As the price of stainless steel decking screws is now very reasonable, there is very little cost increase in a project by specifying these screws and the finished product is superior. 14# gauge batten screws are used for fixing decking and are type 17 screws in a 304 Stainless steel. While these are nominally self drilling, the holes should be predrilled and countersunk as otherwise the screws may be overstressed by overdriving and break off. The screw head needs to finish flush with the deck and this is the reason that countersinks must be pre-drilled. Fixing details are given in the construction instructions.

OSA has stainless steel screws made specifically for its decking applications.

Deck fixings need to be somewhat remote from the ends to reduce end splitting that may be initiated by the decking screws restraining cross grain shrinkage. For this reason, decking should cantilever past the outside joist.



**Fig 34 Typical joist framing**

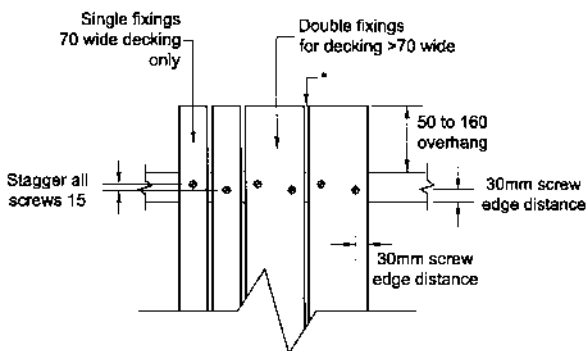

\* Refer to Deckwood Technical Data Sheet for gaps  
All fixings shown 14# SS batten screws

**Fig 33 Deck Screw Spacings**

### Joist Design

The timber used for joists and headstocks is drawn from superior hardwood the properties of which have been verified by In-Grade testing and is designated as Joistwood. The species and surface defects are limited so that they perform satisfactorily as exposed structures. Member design is mostly governed by serviceability requirements so there is a huge reserve of strength.

**Table 22 Bending strength & stiffness for Joistwood (MPa)**

	WSD	LSD
<b>Bending strength f'b</b>	32	78
<b>Short term mod of elasticity E</b>	14400	14400

**Table 23 Joist & Headstock Design Cases (simple spans)**

Live Load Case	Load	Serviceability limit
<b>Uniformly Distributed</b> <i>(foot &amp; cycle)</i>	5 kPa	span/180
<b>Uniformly Distributed</b> <i>(golf car)</i>	5 kPa	span/360

**Table 24 Absolute Maximum Joists Spans for arrangements for 600mm spacings**

Application	Joistwood Size		
	125x75	150x75	200x75
<b>Pedestrian &amp; Cycle</b>	3.0m	3.6 m	4.8 m
<b>Golf Cars</b>	2.4m	2.9 m	3.9 m

### Headstock Design

These joist spans are maxima. The nominated pile spacings should be significantly less as they have to take into account out-of-position driving tolerances as well as the skewness of the headstock introduced by changing the direction of the walk. On mangrove walks and similar, pile positional tolerances may be up to 0.5m different from the theoretical to avoid tree roots and poor underfoot conditions providing a less than ideal platform for the pile driver. If a pile location has to be adjusted, a general rule should be to reduce the longitudinal spacing.

Joists are fixed to headstocks with M12 cuphead bolts. Framing anchors are unsuitable. Locate the bolts to allow tightening of the nuts as timber shrinkage occurs.

75 mm wide joists are recommended to allow staggering of decking screws as this reduces the tendency to propagate cracks in the joists and facilitates connection to the headstock. Malthoid 110mm wide is placed on top of the joist to shield it from moisture penetration and prolong its life.

Vertical load transfer to the post/pile dictates the headstock system. Load transfer can be accomplished by a bolt only or a timber bearing seat (supplemented by a bolt fixing). Bearing seats are often cut poorly resulting in uneven bearing and are sometimes trimmed to the wrong level or orientation. The cutting of the timber post can expose less durable timber in softwood piles while disposal of waste is sometimes of concern to supervisors. Outdoor Structures Australia has adopted the bolted system wherever possible as it is more reliable and almost foolproof but its capacity is limited. For practical deck sizes, a double headstock is needed to reduce bolt loads to acceptable limits.

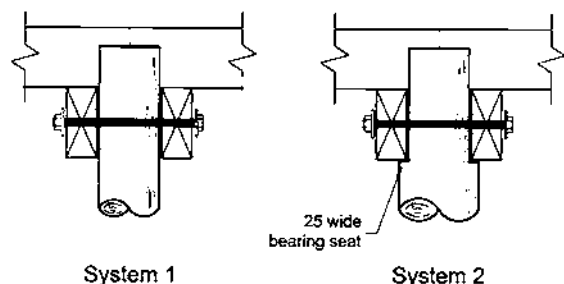

**Table 25 Headstock Joint System short term (5 hour) capacity as per Fig 35**

Bearing Seat	WSD	LSD
no	17.7 kN	24 kN
yes	40 kN	56 kN

**Table 26 Headstock Application**

System	Bolt dia.	Bearing seat	Limitation for 3m pile spacings
1	M20	no	2/150x75 Joistwood headstocks Deck widths to 2m Normal & Golf Car loads Piling 150 Φ J3 min joint group
2A	M20	yes	2/150x75 Joistwood headstocks Deck widths to 2.6m Normal & Golf Car loads Piling 200 Φ J3 min joint group
2B	M20	yes	2/200x75 Joistwood headstocks Deck widths to 3.5m Normal & Golf Car loads Piling 200 Φ J3 min joint group

A single M20 bolt is the practical maximum and bolt edge spacing limitations require a minimum headstock depth of 150 mm. Bolt fixings for joists dictate that headstocks be 75 mm wide, so for most applications double 150x75 headstocks have been adopted.

The galvanized M20 bolt, together with an epoxy coating, provides a robust connection that has high corrosion capacity. For uniformity and to facilitate some handrail systems, it is appropriate to use posts/piles turned to uniform diameters. For low height walkways, 150 mm uniform diameter posts are most suitable enabling uniform bolt lengths to be ordered. These are only available as treated plantation softwood poles.

With increasing deck width or pile spacing, the strength/stiffness of the headstock becomes critical and so a larger size together with a stronger connection and higher capacity pile may be required. While a third pile could be placed at the middle of the group, the additional post/pile can be difficult to align as discussed elsewhere in this document.

In situations where additional span lengths (beyond 3m) or widths (beyond 1.8 m) increase the connection load, load bearing seats must be adopted. In those cases, larger diameter piles are called for (to increase the skin friction because of the increased load being carried) so it is appropriate then to adopt bearing seats that maintain 150 mm between the headstocks so

that handrails and bolt lengths remain the same for consistency and to reduce inventory.

### **Handrail Loading**

In low risk situations, a draped rope or steel chain may suffice to define the extent of the deck; coaxing pedestrians to remain on the boardwalk. Where proper handrails are installed, they have to resist both lateral and vertical loadings.

Rails and stanchions need to resist simultaneous loads, horizontal and vertical, of 0.75 kN/m (*AUSTROADS 2004 Bridge Design Spec., NAASRA 1976 Bridge Design Spec. & AS 1170.1*). AustRoads requires a stiffness such that the rails do not deflect more than span/800 and stanchions:- post height/500. This stiffness requirement is unrealistic for timber. A limit of span/400 for handrailing has been adopted as more suitable for this material. Additionally AS 1170.1 requires 3 kN/m lateral load to restrain crowds e.g. platforms for crowds watching performances, panic situations such as exiting a sporting ground etc.

Deckwood (handrail)	Max Span (span/400)
75x75	2.2 m
100x100	3.6m

**Table 27 Maximum Handrail Span for 0.75 kN/m**

Practical handrail sizes (100x100) restrict post spacing to 3.5m or so and this is also the limit of 150mm deep Joists. Where larger joists are used, support for the handrails from intermediate supports are required.

### Kerbs

It is recommended that kerbs resist vertical and lateral loads of 0.75 kN/m. 75x75 Deckwood kerbs, 3.5 metres long, meet this criteria when continuous over a central support block (3 supports). For golf cars a larger kerb is recommended to serve as a partial vehicle barrier. A 125x125 Deckwood kerb spaced 150mm above the deck should prevent the tyre climbing the kerb in most impacts. Where additional protection is required, railings can be installed.

### Marine Mud

Often boardwalks are located in marine mud. Discounting the support offered by vegetation's surface roots, if the bare ground cannot support a person's weight, the safe bearing capacity is less than 20 kPa.



Fig 37 Bedlog installation on poor ground

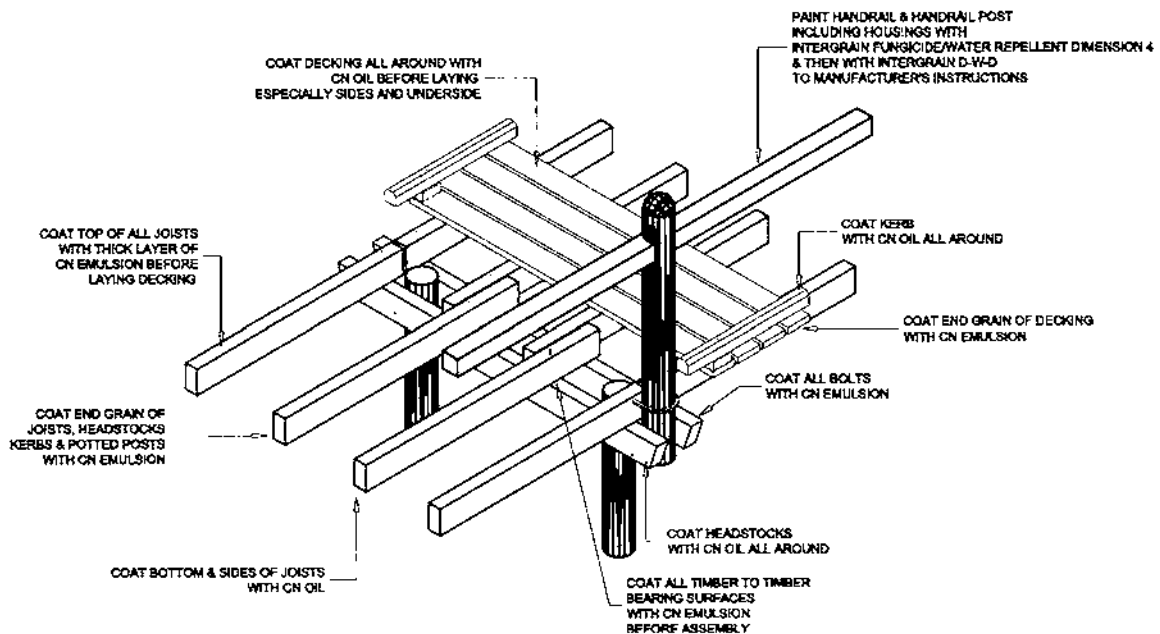

Fig 36 Typical System

## Substructure

### Foundations

Foundations for boardwalks are often very poor soils with high watertables but there is also a large variability in foundation conditions for long boardwalks. Design Pier Loads of 35 kN (LSD) are typical for decks 2 m wide and supported every 3 m by a pair of posts (assuming a reduced average Live Load of 4kPa).

Unfortunately this is about half the intensity of the so-called Low Bearing Pressure crawler machines and so equipment often has to work from timber mats to distribute loads over an even larger area.

In mud, the only practical solution is to drive piles. Timber piles are most effective as they facilitate connection and trimming and do not rust. While piles may carry the load down to a stronger layer buried under the mud, most sites have alluvium so deep that friction piles have to be used. Then virtually the whole load from the structure is transferred to the ground by the friction between the timber pile and the ground. For this to be effective, the embedded surface area of the pile has to be significant.

Ground Conditions	Soft Ground	Watertable	Stiff Ground	Rock
Pier Type	Piled or Bedlog		Potted	Drilled

TABLE 28 - Pier Type Summary

Advantages of timber over steel piles:

- larger friction (surface) area for same unit cost means shorter pile
- easier to trim
- easier to make top connection
- easier splicing
- easier to handle
- larger lateral resistance

Small pile drivers are normally used as:

- smaller zone of disturbance to vegetation
- small load and light piles
- smaller mats required pile frame can fit under trees with minimal disturbance of tree canopy.
- less mass of piling plant means less risk and consequence of bogging.

Pile lengths typically range from 3 m to 8 m but lengths up to 24 m have been used. A drawback of a small pile frame is that piles have to be spliced as the short pile leaders may not allow piles more than 3.6 m long to be pitched. Also this is about the limit for carrying the piles in manually. This has several disadvantages:

- splices have to be kept well under the surface so that lateral resistance is developed without resort to cross bracing
- steel splices may corrode if oxygen is not excluded
- tension capacity reduced significantly (but this is only called on in extreme loadings)



**Fig 38 Small pile driver has small footprint**

Control of pile location, verticality and driving may be less than what is called up in the Piling Code (AS 2159) due to the poor ground conditions and restrictions of the site. For these reasons, it is best to have only two piles in a bent as three or more piles in a bent (group) introduce alignment problems when joining them with a continuous headstock. For the same reason, it is best not to let driven piles protrude to form the handrail. Installing the handrail stanchions later allows control of verticality and some control over position.

Of course, within the tidal range, barge based pile driving is a possibility but barge size and draft usually limit this option. Manual driving of friction piles is not an option as monkey weights of more than 100 kilograms are required. In certain foundation conditions, jetting (*eroding the ground around the pile with water and air introduced by a steel lance attached to the pile*) may be used.

Marine organisms attack timber below the high water mark and so those timbers have to be specially selected, treated or shielded.

### **Soft Ground**

When the surface bearing capacity is 50 kPa or better with the deck height closely following the ground as in freshwater swamps or similar, a bedlog system may be used. A large slabbed log is placed horizontally on a prepared base of gravel and the boardwalk installed on top. If any settlement occurs, the system may be easily re-levelled by jacking and packing. Minimal excavation and equipment are needed so the presence of water is not a problem. Bedlogs and prefabricated decking may be moved on trolleys over the completed deck, minimizing site work.



**Fig 39 Bedlog System**

## Stiff Ground

Ground that has a bearing capacity of 100 kPa or better and no significant watertable can be readily excavated to form a base using a potted post system. Excavation is neatly done with an auger mounted on a Bobcat or similar so access limitations are not usually a problem. Timber can be placed exactly in position and plumbed and secured during backfilling so these verticals may protrude above the deck to form the handrail system if required. In that situation, headstocks will have to span further.

Again from an appearance and cost point of view, it is usual to design posts as freestanding (cantilevering) so that permanent diagonal bracing is not required. When the ground conditions are such that embedment (necessary to develop full bending strength) is not possible (rock near the surface), other bracing systems have to be explored.

The presence of a watertable within the embedment zone can make the hole excavation unstable so driven piles may be resorted to. In that situation, preboring the ground may assist in improving the alignment of the driven posts.

Hardwood posts decay prematurely when concreted in excavated holes so compacted gravel backfill has to be used. This requires more labour and can be a problem maintaining posts in line while compacting the gravel. Hardwood posts are not available in small consistent diameters and they are not as convenient as pine posts. When potted poles are used, the preferred system is treated, parallel sided pine posts with concrete backfill.

## Sand

Piles may also be installed in sand using jetting and this may reduce equipment size. Potted piles are not recommended unless the sand is very compact, dry and, at least, weakly cemented. A high watertable may cause a quick condition precluding excavation. While expensive dewatering options can counteract this, driven piling is often the answer.

Sand has poor lateral capacity. Where this is a problem, buried deadmen can increase lateral resistance by distributing horizontal forces over a larger area. Sand is easily scoured by wave and flood. On coastal dunes, the fine grains are eroded by the wind. It is prudent to make some allowance for this loss of support to the lateral stability of the structure.

## Rock

Sometimes these structures are built to traverse a rock slope. Foundations in rock are a problem, cost more and are more difficult to set out. While posts can be potted into some weak rocks (*600mm minimum*), rock is generally resistant to pier excavation. The rock drills or coring machines are required to drill holes of 75 to 100 mm dia. about 400 mm deep to accept steel supports. The lateral forces have to be resisted by other means for decks over one metre or so.



Fig 40 Steel stirrup in cored hole in sound rock

Other means include:

- welded steel frames
- inclined posts
- bracing back to other stiff points
- X bracing
- moment base plates

Where rock floaters are encountered, or where weathering is variable, it is important that the rocks to be drilled are themselves stable and of sufficient size to provide support. Often smaller rocks may be moved by equipment, hydraulic jacks or explosives to allow a normal excavated pier.

## Slope Stability

Usually most natural slopes are stable but, once the slope is made steeper by earthworks, there may be some downhill movement due to the increased weight of the formation. The use of boardwalks reduces this problem as the mass of the system is very much less than the equivalent earthworks and should maintain the existing stability. Look for signs of recent instability including scours. Crevices, steep gullies, sloping vegetation are all danger signs. Avoid these areas if possible, by picking a more stable route.

## Wetland Boardwalks

These additional requirements are for boardwalks constructed over water.

### **Marine**

In salt (*marine*) water, and even in brackish water (20 kilometres from the mouth of most rivers), live borers attack timber. Most of the attack is below high water and is worse closer to the equator.

Various options can be adopted for timber within that zone:-

- use naturally resistant species
- pressure treat (*usually double treated i.e. both water borne and oil borne preservatives are used together e.g. CCA + Creosote*)
- envelope completely, but still need durable timber
- adopt a non-timber solution (*and with all the problems that it entails*)

### **Fresh Water**

Foundation timbers for freshwater (*and including in-ground with no groundwater*) need to be rated for In-Ground Durability 1 or 2 with any sapwood treated H5.

In-Ground Durability 2 timber in the substructure is permitted in most boardwalks as the difficulty in replacing it is not great. Where the superstructure is significant or the deck very large, consideration may be given to exclude Durability 2 foundation timbers as the difficulty of replacement may outweigh the use of Durability 1 in the original construction.



**Fig 41 Marine boardwalk at high tide**

For exposed piles, the hazard level for preservative treatment is H6 and, even if an enveloping pipe is installed, piles must be treated to at least H5 level. In recent times H4 treatment has become the norm for (*non-critical*) landscape timber so the end branding must be checked to see that timber has been treated to the correct level. There must not be holes or cuts to the treated material within the tidal zone therefore the use of diagonal bracing to resist lateral load is limited.

## Deck Alignment

### Deck Level

A low deck is more economical and less obtrusive but the final level is normally controlled by extreme water levels, especially in wetlands and creeks.

Factors to be considered in deciding on a deck level:-

- HW (high water) mark (for protection against marine borers)
- HAT (highest astronomical tide) is the largest tide for the year
- Storm surge (additive to at least HW but it is possible for this to occur during the highest tide HAT).
- Wave action (additive to above as is during storms and cyclones) and this depends on the fetch (length of water over which the wind acts)
- Shelter from wave action (e.g. mangroves)
- Consequences of overtopping (damage to structure)
- Greenhouse effect (increase in water level in the future) depending on the life of the facility.
- Flood level for structures further up rivers where tidal effects are less controlling.

Other factors to be considered include:

- wind action but this is generally of no consequence unless railings are substantial or buildings e.g. birdhides are constructed on top.
- erosion due to tidal or flood action removing lateral support to piles/foundations
- disaster prevention from an abnormal combination of weather circumstances e.g. tying the structure together so that damaged sections may be supported by intact ones so that parts do not become a navigation hazard.
- light craft loadings where it is possible that small boats may tie up to the structure during maintenance or operations.

Data on water levels may be available from the Local Council. The usual water levels are evident from the existing surface (giving some thought to the current season and recent rainfall) as well as the nature of the vegetation and underfoot conditions. Recent flood levels may be indicated from debris left in trees and shrubs or from talking to adjacent landowners.

Usually, if there is a natural or artificial water level control structure (e.g. weir), the water level can be maintained in a close range so that the deck can be located just above the water (typically 500 mm). Usually the controlling scenario is flooding but, in many situations, the boardwalk is located in a shallow backwater where the stream velocity is low.

## Lateral Loads

Lateral forces are generated from:

- wave action
- wind
- walking
- vehicle braking
- seismic activity
- floodwater including debris
- moored craft

These loads are significant to the substructure design. Debris can come from floodwaters or from wave action associated with storms or cyclones. Debris that has to be removed by hand includes grass, plastic and sea grass. More substantial water-borne rubbish such as trees and branches may have to be sawn into more manageable portions for removal. While design procedures for log impact and such are established for bridges (AustRoads), lightweight boardwalks are usually not robust enough to take the loadings without considerable extra expenditure.

Usually any damage caused is confined to a small section while the temporary loss of the facility (during repair) is acceptable and so designing for log impact is not recommended.

In a marine location, any break to the treated pile envelope to provide diagonal bracing can be a source of deterioration, especially where it presents a lodgement point for marine borers. For this reason, bolted cross bracing is not used. Instead lateral capacity is best achieved by the inherent bending stiffness of the timber pole cantilevering out of the ground. This is the main reason splices must be kept well underground. Failing this, piles can be raked (*inclined to the vertical*) so that lateral loads can be taken axially rather than in bending. Sometimes other bracing systems have to be resorted to, to achieve a stiff deck.

A 1.5 kN load at deck level should be applied to each post as a very minimum.

### Fabricated Steel

In general, use of metal brackets is restricted as the situations (*exposure, treated timber and often salt spray*) are very corrosive. While a low profile deck could be achieved using steel joist hangers, they are not recommended for the same reason. All metalwork is galvanized and an additional paint system is used where it is in contact with timber.

Fabrication in 304 stainless steel is used where corrosion is a problem. Usually this steelwork is not particularly exposed so the extra cost of the 316 SS (*marine grade*) is not warranted. 316 SS is used for handrails for prestigious projects where 'tea staining' may be objectionable.

## SOUTH EAST QUEENSLAND FOREST AGREEMENT

Like many parts of the world, the Queensland forest industry was not immune from the pressure brought upon it by environmental groups. For some time there had been uncertainty that the harvesting of native hardwoods from state forests would continue and consequently investment in the industry was low.

On a national level, Australia had decided to resolve the issue by a lengthy bureaucratic process which applied a "science" based approach to determine what areas could be logged and how heavily and how often. Unfortunately this approach was not universally received by the stakeholders.

The Queensland timber industry took a different approach and talked with government and the key environmental groups to seek a solution. The timber industry accepted the insistence of environmental groups in maintaining biodiversity through large protected areas while the environmental groups accepted the economic importance of sawmilling to rural regions where it is centred.

From this was born the 1999 South East Queensland Forests Agreement (SEQFA). To date it remains the only Australian forest agreement with the acceptance of key environmental groups. The SEQFA covers an area of Queensland that extends north to Rockhampton and west to Toowoomba. These state forests produce 54,000 cubic metres of logs each year. This is the region from which OSA draws the raw material for its external timber structures.



**Fig 42 Selecting tree for felling**

Under the agreement, 400,000 hectares of state forests were transferred to conservation reserve. The remaining state forests will continue to be logged, but only once, before also becoming conservation reserves by 2025. This gives sawmillers access to these forests for this limited period before changing to plantation logs.

This certainty has seen the industry invest heavily in the new machinery needed to process more efficiently the changing nature of the resource. The SEQFA means that the timber can be used with confidence of its environmental credentials.

This agreement has impacted on the size and quality of logs. Log size has fallen 20% while the quality has dropped somewhat making appropriate grading of the sawn timber even more important. This means that the days of heavy section, high-grade timber, that many designers were used to, are gone. Timber sections in this Guide reflect the sizes that will be available for new structures, future maintenance and modification. Keeping member lengths less than 3.6m is now more important to maximize the yield of each log.

**An informative article on the agreement can be found in the July 2000 issue of NATIONAL GEOGRAPHIC in the article entitled "Australia—A Harsh Awakening," available at <http://www.nationalgeographic.com/.ngm/0007/fngm/index.html>.**

### Conclusion

Outdoor Structures Australia prides itself on its expertise in rugged external public structures including shelters, walls, bridges, barriers and boardwalks. It is committed to innovation while retaining what is best of traditional practice in outdoor timber structures.

Boardwalks are an important part of the range of products and can be adapted and customized to the client's requirements. Detailing of decking layup, junctions and handrailing can all be modified to suit a client's theme. Such is the versatility of this style of construction.



**Fig 43 Boardwalk over causeway**



## REFERENCES

**AS** - refers to an Australian Standard as numbered.

**BCA** - refers to the Building Code of Australia.

**Outdoor Structures Australia CO.**  
110 Old College Road, Gatton, Queensland, Australia Q 4343  
PO Box 517 Gatton, Queensland, Australia Q 4343

Phone (07) 5462 4255

Fax (07) 5462 4077

Email [ted@outdoorstructures.com.au](mailto:ted@outdoorstructures.com.au) - Home Page <http://www.outdoorstructures.com.au>

© Outdoor Structures Australia 1998, 2005

Issue 2 -/08/05

## References

- AS 1428-2003 : Design for access and mobility  
AS 1720.1-1997 : Timber structures - Design methods  
AS 2156.2-2001 : Walking tracks: Infrastructure design  
AS 2159-1995 : Piling - Design and installation  
AS 5100-2004 : Bridge Design  
Building Code of Australia  
Deckwood Selection Guide - 2005: Outdoor Structures Australia, Revision 3  
HB 69.14-1995 : Guide to traffic engineering practice - Pedestrians  
HB 69.14-1999 : Guide to traffic engineering practice Bicycles  
NAFI - 1989 : Timber Decks - Commercial Industrial & Marine, Timber Datafile Timber Manual  
NAFI - 1989 : Timber in Landscape, Timber Datafile Timber Manual

### **Deckwood and the smaller LifePlus® Decking are the subject of the following Australian Intellectual Property Registration:**

- Australian Innovation Patent No AU2003100493 (Examined and Certified).  
Australian Design Registration No AU155986.  
Australian Design Registration No AU157321.  
Australian Standard Patent Application No Au2003204845.  
Australian Registered Trademark No 96541(LifePlus & Life+)

### **LifePlus® Decking is also the subject of a number of granted and pending international Patents, Designs and Trademarks, including:**

- Patent Cooperation Treaty Application No PCT/AU2004/000825  
New Zealand Design Application, corresponding to AU Design Application 2106/2003  
New Zealand Trademark Registration No 707428  
Allowed US Design Patent Application No 29/195905  
Japan Design Registration No 1220160  
UK Design Application, corresponding to AU Design Application 2106/2003

**Compiled by James Pierce & Associates, Consulting Engineers,  
for**

### **OUTDOOR STRUCTURES AUSTRALIA**

**Telephone:(07) 5462 4255  
Email: ted@outdoorstructures.com.au  
Facsimile: (07) 5462 4077  
Website: www.outdoorstructures.com.au**

The information and recommendations contained in this Manual have been prepared with due care. They are offered for the purpose of providing useful information to assist in the specification of Boardwalk design. Outdoor Structures Australia reserves the right to change or, cease to manufacture, any of the boardwalks represented in this Manual.

Whilst every effort has been made to ensure that this Manual is in accordance with current practice, it is not intended as an exhaustive statement of all relevant information. As successful design and construction depends upon numerous factors outside the scope of this Manual, Outdoor Structures Australia and James Pierce & Associates accepts no responsibility for errors in, or omissions from the Manual, nor on designs or work done, or omitted to be done, in reliance on the Manual.



**TANALISED®**

**Outdoor Structures Australia**

110 Old College Road, Gatton Queensland 4343  
PO Box 517, Gatton, Queensland, Australia 4343

**Telephone: (07) 5462 4255**

**Facsimile: (07) 5462 4077**

**International Telephone: + 61 7 5462 4255**

**International Facsimile: + 61 7 5462 4077**

**Email: [ted@outdoorstructures.com.au](mailto:ted@outdoorstructures.com.au)**

**Website: [www.outdoorstructures.com.au](http://www.outdoorstructures.com.au)**



WOOD PROTECTION



**Outdoor Structures  
Australia**  
*outlasts and outperforms*